

25 JAHRE
YEARS

THALER

Wir verstehen, was Sie brauchen!

Because we know what's important!



Qualitäts Lader „Made in Germany“
High-Quality Loader „Made in Germany“



15. Sep. 1997
von Johann
& Manfred
Thaler gegründet

founded
15. Sept. 1997
by Johann &
Manfred Thaler



Entwicklung
& Produktion
in Deutschland

Development
& Production
in Germany

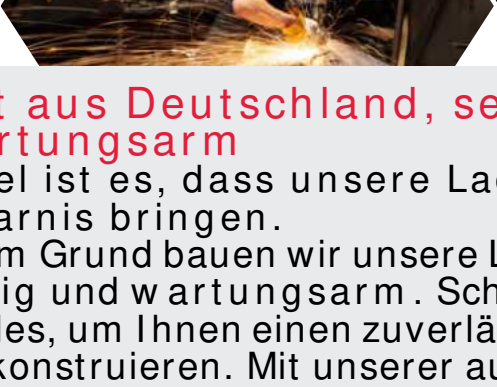
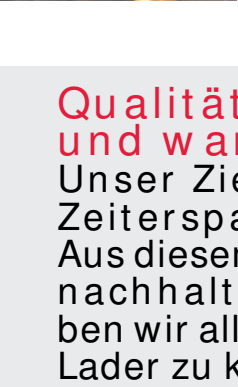

Qualität aus Deutschland, servicefreundlich und wartungsarm

Unser Ziel ist es, dass unsere Lader Ihnen Arbeits- und Zeitersparnis bringen.

Aus diesem Grund bauen wir unsere Lader möglichst langlebig, nachhaltig und wartungsarm. Schon bei der Entwicklung geben wir alles, um Ihnen einen zuverlässigen und wartungsarmen Lader zu konstruieren. Mit unserer ausgeklügelten Konstruktion gewährleisten wir die Zugänglichkeit aller wichtigen Wartungspunkte sowie einen ergonomischen Arbeitsplatz. Zudem verbauen wir nur hochwertige Zukaufkomponenten, Filter und Öle. Über unser Netz aus Händlern, Importeuren und Werkstätten bieten wir Ihnen immer einen Ansprechpartner sowie persönlichen und zuvorkommenden Service. Mit unserer Inhouse-Ersatzteil- und Serviceabteilung stehen wir Ihnen telefonisch sowie per E-Mail bei Fragen zur Verfügung.

Grundsätzlich setzen wir auf bewährte Technik und verbauen mehr hydraulische als elektrische Lösungen. **Warum?** Ganz einfach: Der Austausch eines Hydraulikbauteiles ist wesentlich einfacher und günstiger als eine teure Elektronikreparatur. Zudem achten wir auch auf komfortable Zugänglichkeit aller zu wartenden Teile.





Quality from Germany, service-friendly and low-maintenance

Our goal is that our loaders save you time and work. For this reason, we build our loaders to be as durable, sustainable and low maintenance as possible. Right from the development stage we do everything we can to construct a reliable and low maintenance loader for you. With our ingenious construction, we guarantee accessibility to all important maintenance points as well as an ergonomic workplace. In addition, we only install high-quality purchased components as well as filters and oils. By means of our network of dealers, importers and workshops, we always offer you a contact person as well as personal and courteous service. With our in-house spare parts and service department we are available for you by telephone and email if you have any questions.

über
70 Mitarbeiter
produzieren Ihren
Lader auf 17.000 m²

over 70 people
produce your
loader on
17,000 m²

We rely on proven technology and install more hydraulic than electrical solutions. **Why?** It's simple: Replacing a hydraulic hose is much easier and cheaper than an expensive electronic repair. We also ensure that all parts requiring maintenance are easily accessible and that your loader is easy to operate.



Ausbildung
eigener Fachkräfte
seit 2006

Training of new
qualified people
since 2006

4 Radnabenmotore

1x Ölmotor
pro Achse

Radialkolbenmotor
und Kardanwelle

Axialkolbenmotor
und Kardanwelle

4 wheel hub engines

1x oil engine
per axle

radial piston engine
and cardan shaft

axial piston engine
and cardan shaft

20 PS

20 HP



1220



2220



2320

25 PS

25 HP



2226



2326



2230

38 PS

38 HP



2438

48 PS

48 HP

5-Achstenker / 5-axis-steering loader



3448-5A



3448 T-5A

72 PS

72 HP

otor
elle
ine
ft

Axialkolbenmotor + Kardanwelle + Planetenantrieb
axial piston engine + cardan shaft + planetary drive



Unsere Lader sind mit unterschiedlichen Hubhöhen erhältlich:

L-Version: Hohe Lasten
S-Version: Standard Lasten
H-Version: Geringe Lasten
T-Version: Teleskop

Our loaders are available with different heights of the shovel pivoting point:

L-Version = Low version for big tipping loads
S-Version = Standard height for standard performances
H-Version = long boom for higher reach
T-Version = Telescopic boom

Teleskopradlader

Telescopic loader

Teleskoplader

Telehandler



2838



2838 T



3448



3448 T



48T18



4275T

Alle Lader erfüllen
EU Abgasstufe V

All loaders are EU
Stage V conform

Schmale Stalltüren oder Gartentore?
Kein Problem für den 1220!

verfügbare Anbaugeräte:
available Attachments:

- Schaufel
Bucket
- Leichtgutschaufel
High volume bucket
- Schaufel mit Aufsatz
Bucket with hydraulic grab
- Krokodilgebiss
Fork and grab
- Palettengabel
Pallet fork
- Kehmaschine 1,20m
Sweeper 1,20m
- Sichelmäherwerk 1,20m
Rotary mower 1,20m
- Ballenspieß
Bale fork
- Gülleschieber
Manure scraper
- Gummischieber
Rubber scraper



600 kg

Kipplaster
Tipping load



Small helper at Home and at the Farm.

Narrow stable doors or garden gates?
No problem with the 1220!



1,99 m

Standardbreite: 0,88m
Breitbereifung:
1,08m o. 1,16m

Total width with
standard tires: 0,88m
Wide-based tires:
1,08m or 1,16m



großer Fußraum ohne Stolperfallen wie Mitteltunnel
large footwell without tripping hazards such as centre tunnel

robuste Bauweise aus Stahl
long-lasting steel construction



permanenter Allrad
permanent four-wheel drive

optional Zusatzgewicht
mit Abschleppvorrichtung
optional with additional weight with towing device

vollhydrostatischer Antrieb
für ideale Fahrleistung und Sicherheit
hydrostatic drive for ideal driving performance and safety



Antrieb / Transmission
Ein Hydrostat versorgt die Ölmotoren.

The hydrostatic pump supplies oil to the hydraulic.



Fops/ Rops Schutzdach
Fops/Rops protection cage



Fahrer-Sicherheit
Alle Thaler-Lader mit patentiertem Fahrer Rückhaltesystem nach aktueller Maschinenrichtlinie zum Schutz des Fahrers. (ohne Bügeltür)

Driver Protection
All Thaler loaders with patented driver restraint system in accordance with the current Machinery Directive to protect the driver. (without hangerdoor)



Knickwinkel 55°
articulation angle 55°

verschiedene
Reifenoptionen
für alle Modelle
different tire options
for all models



Optional Breitreifen verfügbar

Optional wide-based tires available

LED Arbeitsscheinwerfer
für optimale Ausleuchtung
des Arbeitsbereichs
LED worklights for optimal
illumination of the working area



verschiedene Aufnahmen und
Schwingen möglich
different coupling systems and
boom options available



ideale Wartungszugänglichkeit
**durch nach oben zu öffnende
Motorhaube**
ideal maintenance accessibility due to
engine hood that opens upwards



**Was macht unsere
2320 & 2326 einzigartig?**

Durch die technische Entwicklung des Radialkolbenmotors direkt auf der Achse gepaart mit der Kardanwelle bieten wir mit dem 2320 und 2326 eine kompakte 20 bzw. 25 PS Maschine mit optimierter Schubkraft und erhöhter Geschwindigkeit.

**(2320 - 1-stufig bis zu 15 km/h)
(2326 - 2-stufig bis zu 20 km/h)**

**What makes our
2320 & 2326 unique?**

Through the technical development of the radial piston engine directly on the axle paired with the cardan shaft, we offer with the 2320 and 2326 a compact 20 or 25 HP machine with optimised thrust and increased speed.

**(2320 - 1 stage - up to 15 km/h)
(2326 - 2 stage - up to 20 km/h)**



Rahmen
baugleich 22xx

Frame identical in
construction to 22xx



verstellbare Lenksäule
adjustable steering column



alle Schmiernippel
nach außen verlegt
all grease nipples
moved to the outside



einfacher Einstieg
easy access



überdurchschnittlich
hohe Kühlleistung
above average
high cooling capacity



optional Anfahrerschutz
optional collision protection





Der Hoflader 2230 überzeugt als kompakter, wendiger Allrounder (Kipplast 1,3t, Überladehöhe 2,58m) Der Stufe V, 25PS Dieselmotor mit 1331ccm Hubraum arbeitet zuverlässig. Kardanwelle und Hydrostat mit Automotiver Steuerung sorgen für optimale Kraftverteilung mit 2 Stufen bis zu 16 km/h. Durch ausgeklügelte Konstruktion verfügt er über einen großen Fußraum ohne Stolperfallen für müheloses Aufsteigen sowie eine gute Übersicht auf den Arbeitsbereich. Standardmäßig: bequemer Sitz, verstellbare Lenksäule, 3. Steuerkreis mit hydraulischer Geräteverriegelung, ergonomischer Joystick und 3 LED-Arbeitsscheinwerfer. Als Multitalent mit vielen verfügbaren Anbaugeräten hilft er Ihnen, sämtliche Aufgaben **effizient und kraftsparend zu erledigen. Lassen Sie sich beraten, wie ein Thaler auch Ihre Arbeit erleichtern kann.**

The 2230 yard loader is a compact, manoeuvrable allrounder (tipping load 1.3 t, overload height 2.58 m). The stage V, 25 hp diesel engine with 1331ccm displacement works reliable. Cardan shaft and hydrostat with automatic control ensure optimized power distribution with 2 stages up to 16 km/h. Sophisticated design gives it a large footwell without trip hazards for effortless climbing and a good view of the working area. Standard features: comfortable seat, adjustable steering column, 3rd control circuit with hydraulic implement lock, ergonomic joystick and 3 LED work lights. As an allrounder with many attachments available, it helps you to complete all tasks efficiently and with minimum effort. Let us advise you on how a Thaler can also make your work easier.

größtes Modell
ohne Abgasnachbe-
handlung
biggest loader
without exhaust
aftertreatment (DPF)



Unser Allrounder kommt nicht nur in der Landwirtschaft gut an. Our allrounder is not only popular in the agricultural industry.





verfügbare Aufnahme Systeme available coupling systems

Thaler alt (4-Kant)
Thaler old (rectangular)



Thaler-Haken-Aufnahme
Thaler hook bracket system



Euro-8-Aufnahme
Euro Recoupling system



Werkzeuge mit der Thaler (alt) 4-Kant-Aufnahme kompatibel zur heutigen Thaler-Haken-Aufnahme. Weitere Aufnahmen auf Anfrage.

Tools and attachments with the original (old) Thaler Rectangular Tube hitching System are compatible with the today's current Thaler hook bracket system.

For further quick coupling system such as SMS or coupling systems of other makes please contact your local dealer.



Robustes, wartungsarmes
Knickpendelgelenk

Centre pivoting articulation
is a very robust, low-
maintenance construction



Einhebelbedienung
& verstellbare Lenksäule

Single lever multi-functional joystick
and adjustable steering column



Option: absenkbares Dach
Option: hydraulic lowerable roof

Mit dem preisgekrönten und patentierten absenkbaaren Fops-Rops Dach können Sie das Dach um 25 cm absenken.

Optional für 2220 - 3448

With the distinctive and patented in height adjustable ROPS-FOPS Protection cage you can lower the roof by 25 cm.

Option on 2220 – 3448



Hervorragende Übersicht

Excellent overview



Alle Schmierstellen sind nach außen gelegt

All lubrication points are well positioned for easy access



Ideale Wartungszugänglichkeit

Ideal accessibility for maintenance and service

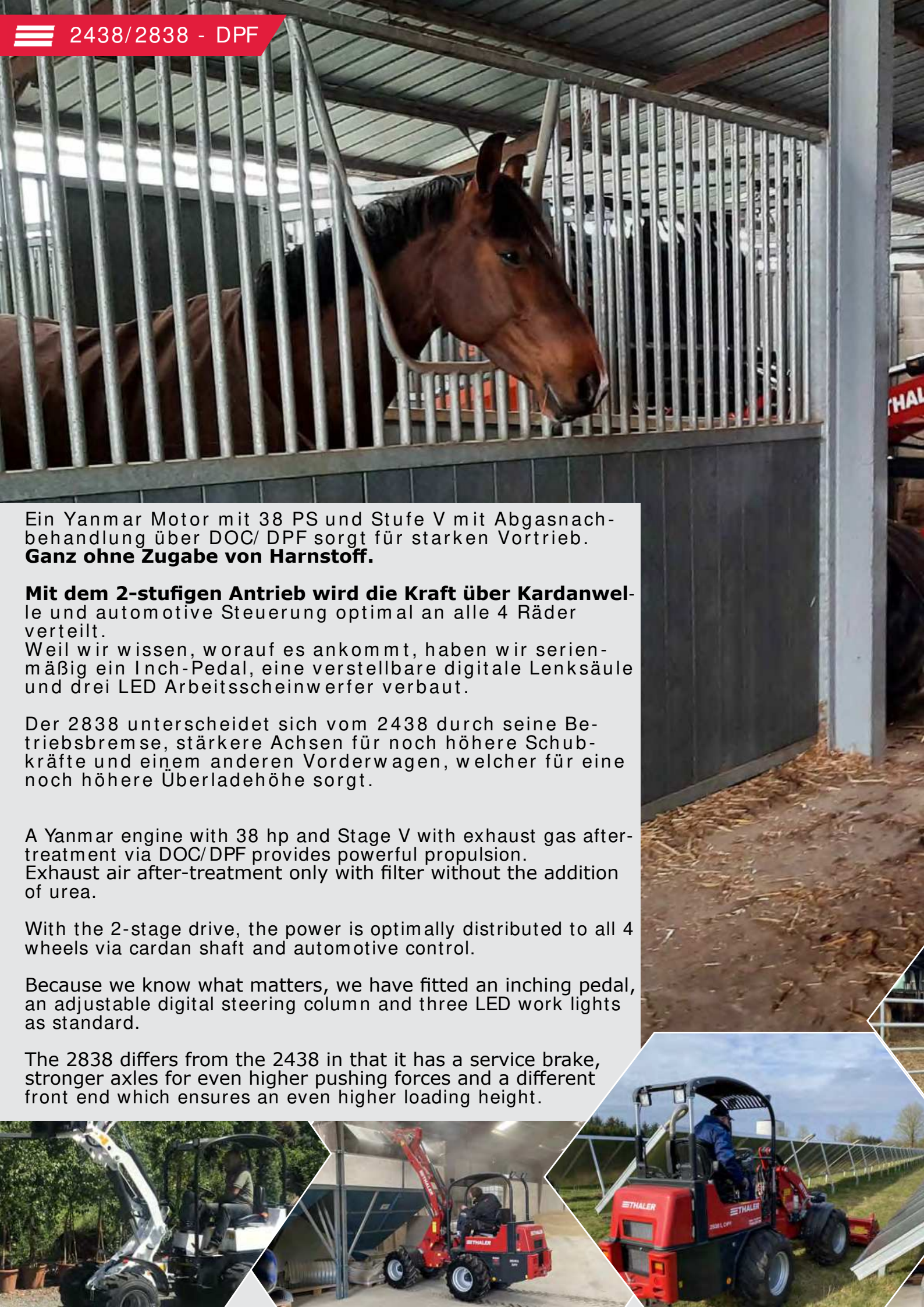

Ein Yanmar Motor mit 38 PS und Stufe V mit Abgasnachbehandlung über DOC/ DPF sorgt für starken Vortrieb.
Ganz ohne Zugabe von Harnstoff.

Mit dem 2-stufigen Antrieb wird die Kraft über Kardanwelle und automotiv Steuerung optimal an alle 4 Räder verteilt.

Weil wir wissen, worauf es ankommt, haben wir serienmäßig ein Inch-Pedal, eine verstellbare digitale Lenksäule und drei LED Arbeitsscheinwerfer verbaut.

Der 2838 unterscheidet sich vom 2438 durch seine Betriebsbremse, stärkere Achsen für noch höhere Schubkräfte und einem anderen Vorderwagen, welcher für eine noch höhere Überladehöhe sorgt.

A Yanmar engine with 38 hp and Stage V with exhaust gas after-treatment via DOC/DPF provides powerful propulsion. Exhaust air after-treatment only with filter without the addition of urea.

With the 2-stage drive, the power is optimally distributed to all 4 wheels via cardan shaft and automotive control.

Because we know what matters, we have fitted an inching pedal, an adjustable digital steering column and three LED work lights as standard.

The 2838 differs from the 2438 in that it has a service brake, stronger axles for even higher pushing forces and a different front end which ensures an even higher loading height.





Starke Motoren für starke Hoflader!

Wir bei Thaler halten nichts von Unter-**motorisierung der Hoflader. Daher erhalten Sie bei uns die Hoflader nur mit dem** Motortypen, der auf die Maschinengröße abgestimmt ist. So passen Maschinengewicht, Motor und Leistung einfach immer zusammen.

Powerful engines for powerful loaders.

At Thaler, we do not believe in underpowering yard loaders. That's why we only supply yard loaders with the engine type that is matched to the machine size. This way, machine weight, engine and power always fit together.

einstellbare Lenksäule
bei allen Modellen
adjustable steering column
for all models

Dieseltank im Vorderwagen
Diesel tank in the front end

verschiedene Aufnahmen
möglich z.B Thaler, Euro, SMS
different coupling systems possible
e.g. Thaler, Euro, SMS etc.



Comer-Achsen
in allen Modellen
Comer axles for all models

2 Lenkzylinder
2 steering cylinders

einfacher Einstieg
easy access

Fops/ Rops Dach für Ihren Schutz
Fops/ Rops cage for your safety

LED-Arbeitsscheinwerfer
serienmäßig
LED-working-lights standard

große Beinfreiheit
ample legroom

Yanmar Motor bei
allen Typen verbaut
Yanmar Engines
mounted in all models

GFK-Haube seitlich
zu öffnen
GRP-hood can be
opened sideways

Fahrerstand nach
oben zu kippen
driver-stand to tilt
upwards

Planetenantrieb mit verschleiß-
freier Lamellenbremse im Ölbad
planetary drive with wear-free
disc-brake in oil bath



Kleiner Teleskopradlader hebt hoch hinaus!

Der Teleskoparm lässt sich um 85 cm ausfahren, was eine Überladehöhe von 3,89 m ermöglicht. Bei einer Standardbreite von 1,38m ist dabei eine gute Standsicherheit gegeben.

Der 38 PS Yanmar Motor erreicht die Stufe V Norm mit **DOC und DPF, ohne dabei Harnstoff zu benötigen. (wie all unsere Modelle)** Bei diesem Modell ist durch den Einsatz von Planetenantrieben besonders guter Antrieb und **Spritzigkeit gegeben. 2-stufig werden 20 km/h erreicht.**

Small telescopic wheel loader lifts up high!

The telescopic boom can be extended by 85 cm, which allows a high overloading height of 3.89 m. With a standard width of 1.38 m, good stability is ensured.

The 38 hp Yanmar engine achieves the stage V standard with DOC and DPF without the need for urea.(as all our models)
The use of planetary drives gives this model particularly good acceleration and lively performance. A speed of 20 km/h can be achieved in 2 stages.



2438/ 2838/ 2838T
auch mit Kabine
erhältlich

2438/2838/2838T
available with cabin





3448 Achsaufhängung mit System

Der 3448 unterscheidet sich von unseren anderen Modellen durch die Pendelachse im Heck mit erhöhter Standsicherheit durch Blattfedern.

3448 Axle suspension with system

The 3448 differs from our other models by the oscillating axle in the rear with stabilisation by leaf springs.



GFK-Motorhaube nach oben zu öffnen

Fahrerstand / Kabine seitlich zu kippen für gute Wartungszugänglichkeit
GRP-engine hood opens upwards
Operator's platform / cab tilts for good maintenance accessibility



auch erhältlich als wendiger 5-Achsenlenker (Allradlenkung + Knicklenkung zuschaltbar)

also available as manoeverable 5-Axis steering loader (All-wheel steering + articulated steering)



Hubzylinder - Sind zwei besser als einer?

Physikalisch betrachtet: Nein. Die Kraft für den Hub entsteht in der Hydraulikpumpe und wird im Zylinder lediglich umgesetzt. Entscheidend ist nicht die **Anzahl der Zylinder, sondern die Öldurchflussmenge**. Weiter wirkt durch einen größeren einzelnen mittig angebrachten Zylinder die Kraft immer zentral am Arm, selbst wenn die Ladung etwas ungleich verteilt sein sollte. Dies trägt zur erhöhten **Verwindungssteifigkeit der Ladeanlage bei**.

Are two lifting cylinders stronger than one?

From a physical point of view: No. The force for lifting the load is generated in the hydraulic pump and is merely converted in the cylinder. The decisive factor is not the number of cylinders, but the oil flow rate. Furthermore, due to a single centrally mounted cylinder, the force always acts centrally on the arm, even if the load should be somewhat unevenly distributed. This contributes to the increased torsional rigidity of the loading system.



optional
mit Kabine erhältlich
optional: available
with cabin



Exzellente Schubkraft durch optimal aufeinander abgestimmtes Zusammenspiel von Hydrostat und Achse.
Excellent thrust due to optimally coordinated interaction of hydrostat and axle.

2,57 m



Pendelachse im Heck für maximale Stabilität
oscillating rear axle for maximum stability

GFK-Motorhaube nach oben zu öffnen, Kabine seitlich zu kippen, für gute Wartungszugänglichkeit
GRP-engine hood opens upwards, cab tilts for good maintenance accessibility



vielseitige Einsatzmöglichkeiten
versatile application possibilities



Mit der Überladehöhe von 4,40m kann jeder Kipper beladen werden.
With the overloading height of 4.40m anything can be loaded.

sehr geräumige Kabine mit geschraubten Scheiben
spacious cabin with screwed glass panels

quer eingebauter Motor für bessere Servicezugänglichkeit
transversely mounted engine for better service accessibility

standardmäßig 40% gesperrte Achsen mit Planetenantrieb
self-locking differential axle (40%) with planetary drive

standardmäßig mit straßentauglicher Beleuchtung
always with lighting system for public road use

45° Knickwinkel
2 Lenkzylinder für gleiche Lenkkraft
45° articulated angle
2 steering cylinder for double-sided steering power

robuste Bauweise bei 4,9t Leergewicht
robust construction with 4,9t empty weight

starre Knicklenkung
rigid articulated steering



erhältlich auch
mit Heckhydraulik
optional available
with rear hydraulic



erhältlich mit
Standstabilitäts-
nachweis für
Arbeitsbühne

available with proof of
stability for lifting platform

Egal ob beim Transport schwerer Paletten, Beladen von hohen Anhängern, Stapeln von Heu und Stroh oder beim Arbeiten auf der Baustelle, mit dem 48T18 sind Sie bestens für anfallende Arbeiten gerüstet. Es besteht die Möglichkeit den Standsicherheitstest für den Einsatz mit einer Arbeitsbühne im Zwei-Mann-Betrieb durch die Dekra abnehmen zu lassen. Zudem ist die Zulassung als Traktor durch den TÜV Süd möglich. Dadurch kann ein gebremster Anhänger mit Anhängelast von 4000 kg transportiert werden.

Whether transporting heavy pallets, loading high trailers, stacking hay and straw or working on the construction site, with the 48T18 you are ideally equipped for any work that arises. It is possible to obtain the Dekra stability certificate for use with a working platform in two-man operation as well as approval as a tractor by TÜV Süd is possible, therefore a braked trailer with a towing capacity of 4000 kg can be transported. The high payload in combination with the working height ensures that there is hardly anything left to be desired. No wish remains unfulfilled.

Nutzlast in Kombination mit der Arbeitshöhe sorgt dafür, dass im Einsatz kaum **noch Wünsche offenbleiben.**



4,80 m

1,80 m

1,99 m



breite Kabinemit Heizung,
Multimediasystem und
Scheibenwischer
wide cabin with heating,
multimedia system and
windshield wipers

LED-Arbeitsscheinwerfer
serienmäßig
LED working lights standard

Yanmar-Motor bei allen
Typen verbaut
Yanmar engine mounted
in all models

GFK-Haube
wartungsfreundlich
GRP engine hood easy
access for maintenance

Pendelachse
oscillating axle

Comer-Achsen in allen
Ladern verbaut
Comer Axles used in all
models

geschlossene Bodengruppe
closed floor assembly



außenliegende Leitungen
outside tubing

einstellbare Lenksäule
adjustable steering column

Armstabilisierung für
Arbeiten im unteren Bereich
Boom stabilisation for work in
the lower area

Straßentaugliche
Beleuchtung (optional)
lighting system for public
road use (optional)

verschiedene Aufnahmen
möglich
different coupling systems
available

extrem niedriger
Schwerpunkt
extremely low centre of
gravity

Planetenantrieb
für hohe Schubkraft
planetary drive for high
thrust

Der 48T18 hebt sich
durch seine extra
breite Kabine von
anderen Teleskopladern
dieser Größe ab.

The 48T18 stands out from
other telescopic loaders
thanks to his very wide
comfort cabin.



		1220	2220	2226	2320
Antriebsart	Transmission	4 Radnabenmotore 4 wheel hub motors	2 Ölmotore 2 oil motors	2 Ölmotore 2 oil motors	Radialkolbenmotor + Gelenkwelle/ cardan shaft+ radial piston engine
PS	HP	19	19	25	19
Motor	Engine	3-Zylinder Yanmar 14,6 kW	3-Zylinder Yanmar 14,6 kW	3-Zylinder Yanmar 18,9 kW	3-Zylinder Yanmar 14,6 kW
Hubkraft	Lifting capacity	750 kg	1500 kg	1400-1500 kg	1500 kg
Standardbereifung	Standard tyres	6,5/80-12BKTAS504	7.00-12 AS	7.00-12 AS	7.00-12 AS
Arbeitshydraulik	Working hydraulic	ca. 33 l/min / 160 bar	ca. 33 l/min / 180 bar	ca. 42 l/min / 180 bar	ca. 33 l/min / 180 bar
Kipplast Maschine gerade (Palettengabel 50cm)	Tipping load machine straight pallet fork 50cm)	600 kg	900-1100 kg	700-1100 kg	900-1100 kg
Kipplast Maschine gerade (Schaufel)	Tipping load machine straight bucket	600 kg	1100-1150 kg	900-1200 kg	1100-1150 kg
Abgasnachbehandlung	Exhaust aftertreatment	nein no	nein no	nein no	nein no
Fahrtrieb	Drive	Hydrostat / 230 bar	Hydrostat / 230 bar	Hydrostat / 230 bar	Hydrostat / 230 bar
Geschwindigkeit	Speed	0-16 (1-stufig)	0-11 (1-stufig)	0-12 (1-stufig)	0-14 (1-stufig)
Hubraum	Displacement	900 ccm	900 ccm	1120 ccm	900 ccm
Kühlung	Cooling	Wasser/Öl-Kombikühler water/oil cooling			
Elektrik/ Batterie	Battery	14V/ 45AH	12V / 45AH	12V / 45AH	12V / 45AH
Dieseltankvolumen	Diesel tank	25l	28-37 l	28-37 l	28-37 l
Hydrauliktankvolumen	Hydraulic oil tank	25l	36l	36l	36l

		2838T	3448T	3448T-5A
Antriebsart	Transmission	Axialkolbenmotor + Gelenkwelle + Planetenantrieb/ axial piston motor + cardan shaft + planetary drive	Axialkolbenmotor + Gelenkwelle + Planetenantrieb/ axial piston motor + cardan shaft + planetary drive	Axialkolbenmotor + Gelenkwelle + Planetenantrieb/ axial piston motor + cardan shaft + planetary drive
PS	HP	38	48	48
Motor	Engine	3-Zylinder Yanmar 28,2 kW	4-Zylinder Yanmar 35,4 kW	4-Zylinder Yanmar 35,4 kW
Hubkraft	Lifting capacity	2000 kg	2500 kg	2500 kg
Standardbereifung	Standard tyres	400/50-15	400/50-15	400/50-15
Arbeitshydraulik	Working hydraulic	ca. 51 l/min / 200 bar	ca. 51 l/min / 200 bar	ca. 51 l/min / 200 bar
Kipplast Maschine gerade (Palettengabel)	Tipping load machine straight pallet fork 50cm)	570-1020 kg	1000-2000 kg	1000 -2000 kg
Kipplast Maschine gerade (Schaufel)	Tipping load machine straight bucket	690- 1320 kg	1200 - 2200 kg	1200 - 2200 kg
Abgasnachbehandlung	exhaust aftertreatment	ja, mit DPF-Filter yes, with DPF-filter		
Fahrtrieb	Drive	Hydrostat / 365 bar		
Geschwindigkeit	Speed	0-18 (2-stufig)		
Hubraum	Displacement	1642 ccm	2190 ccm	2190 ccm
Kühlung	Cooling	Wasser/Öl-Kombikühler water/oil cooling		
Elektrik/ Batterie	Battery	12V / 75AH	12V / 75AH	12V / 75AH
Dieseltankvolumen	Diesel tank	50 l	50 l	50 l
Hydrauliktankvolumen	Hydraulic oil tank	50 l	40 l	40 l



Wir bedanken uns herzlich bei allen Kunden und Händlern,
die uns Anwendungsbilder der Hoflader zur Verfügung gestellt haben.
 We would like to thank all our customers and dealers
 who have provided us with the application images of the loaders.

2326	2230	2438	2838	3448	3448-5A
Radialkolbenmotor + Gelenkwelle/ cardan shaft+ radial piston engine	Axialkolbenmotor + Gelenkwelle / axial piston engine + cardan shaft	Axialkolbenmotor + Gelenkwelle / axial piston engine + cardan shaft	Axialkolbenmotor + Gelenkwelle + Planetenantrieb/ axial piston engine + cardan shaft + planetary drive	Axialkolbenmotor + Gelenkwelle + Planetenantrieb/ axial piston engine+ cardan shaft + planetary drive	Axialkolbenmotor + Gelenkwelle + Planetenantrieb/ axial piston engine + cardan shaft + planetary drive
25	25	38	38	48	48
3-Zylinder Yanmar 18,9 kW	3-Zylinder Yanmar 18,9 kW	3-Zylinder Yanmar 28,2 kW	3-Zylinder Yanmar 28,2 kW	4-Zylinder Yanmar 35,4 kW	4-Zylinder Yanmar 35,4 kW
1400-1500 kg	1300-1600 kg	1400-1700 kg	1800-2200 kg	2500-2900 kg	2500-2900 kg
7.00-12 AS	10.0/75-15.3	10.0/75-15.3	10.0/75-15.3	10.0/75-15.3	400/50-15
ca. 42 l/min / 180 bar	ca. 38 l/min / 180 bar	ca. 45 l/min / 190 bar	ca. 51 l/min / 190 bar	ca. 51 l/min / 180 bar	ca. 51 l/min / 180 bar
700-1100 kg	750-1100 kg	1000-1200 kg	1100-1400 kg	1600-1800 kg	1600-1800 kg
900-1200 kg	1100-1400 kg	1200-1500 kg	1300-1700 kg	1700-1900 kg	1700-1900 kg
nein no	nein no	ja, mit DPF-Filter yes, with DPF-filter	ja, mit DPF-Filter yes, with DPF-filter	ja, mit DPF-Filter yes, with DPF-filter	ja, mit DPF-Filter yes, with DPF-filter
Hydrostat / 260 bar	Hydrostat / 365 bar	Hydrostat / 365 bar	Hydrostat / 365 bar	Hydrostat / 365 bar	Hydrostat / 365 bar
0-18 (2-stufig)	0-16 (2-stufig)	0-18 (2-stufig)			0-20 (2-stufig)
1120 ccm	1331 ccm	1642 ccm	1642 ccm	2190 ccm	2190 ccm
Wasser/Öl-Kombikühler water/oil cooling					
12V / 45AH	12V / 45AH	12V / 75AH	12V / 75AH	12V / 75AH	12V / 75AH
28-37l	28-37l	28-37l	50l	50l	50l
36l	35l	45l	45l	40l	40l

4275T	48T18
Axialkolbenmotor + Gelenkwelle + Planetenantrieb/ axial piston motor + cardan shaft + planetary drive	Axialkolbenmotor + Gelenkwelle + Planetenantrieb/ axial piston motor + cardan shaft + planetary drive
72	48
4-Zylinder Yanmar 53 kW	4-Zylinder Yanmar 35,4 kW
4000 kg	2500 kg
405/70-R20ET+30	10.0/75-15.3
ca. 75 l/min / 180 bar	ca. 60 l/min / 200 bar
2500 kg	580 - 1550 kg
3000 kg	
ja, mit DPF-Filter yes, with DPF-filter	
Hydrostat / 365 bar	
ca. 0-25 (2-stufig)	
3320 ccm	2190 ccm
Wasser/Öl-Kombikühler water/oil cooling	
12V / 100AH	12V / 75AH
50 l	50 l
70 l	50 l

Benutzen Sie unseren Online-Produktfinder oder suchen Sie online nach Ihrem Händler.



Deutsch

SCAN ME



English

SCAN ME

Use our online product finder or search for a dealer online.
www.hoflader.com



Alle Angaben unter Vorbehalt!
Änderungen im Zuge der technischen Weiterentwicklung vorbehalten!
All data are subject to change! Information can change due to further development.

			1220	2220L	2220S	2226L	2226S	2226H	2230L	2230S	2230H	2320L	2320S
A1	Gesamtlänge mit Schaufel total length with bucket	mm	2950	3750	3780	3750	3780	4080	3830	3870	4180	3750	3780
A2	+ Gussgewicht + weight	mm	-	-	-	-	-	-	-	-	-	-	-
B1	Gesamtlänge ohne Schaufel total length without bucket	mm	2480	2990	3020	2990	3020	3320	3094	3110	3420	2990	3020
B2	+ Gussgewicht + weight	mm	-	-	-	-	-	-	-	-	-	-	-
C	Achsmittle bis Schaufeldrehpunkt axle middle to shovel pivot pin	mm	430	530	550	530	550	860	530	550	860	530	550
D	Radabstand / wheelbase	mm	1250	1523	1523	1523	1523	1523	1572	1572	1572	1523	1523
E1	Hecküberhang / Rear overhang	mm	760	830	830	830	830	830	880	880	880	830	830
E2	+ Gussgewicht + weight	mm	-	-	-	-	-	-	-	-	-	-	-
F	Höhe über Fops-Rops Dach height over FOPS/ROPS protection cage	mm	1990	2160	2160	2160	2160	2160	2210	2210	2210	2160	2160
G	Sitzhöhe / seat height	mm	1000	-	-	-	-	-	-	-	-	-	-
J	Gesamtarbeitshöhe/ total working height	mm	2600	2760	3275	2760	3275	3470	2820	3340	3520	2760	3275
K	max. Höhe am Schaufeldrehpunkt max. height at shovel pivot pin	mm	2200	2150	2708	2150	2708	2870	2210	2760	2935	2150	2708
L	Überladehöhe / load-over height	mm	2080	1940	2480	1940	2480	2660	1995	2580	2710	1940	2480
M	max. Ausschütthöhe max. dumping height	mm	1710	1320	1935	1320	1935	2140	1375	2040	2220	1320	1935
N	Reichweite bei M operating distance by M	mm	350	340	325	340	325	530	340	330	510	340	325
O	Schürftiefe / digging depth	mm	0	70	70	70	70	60	25	25	20	70	70
P	Gesamtbreite Standardbereifung total width with standard tires	mm	880	920	920	920	920	920	1120	1120	1120	940	940
Q	Spurbreite / track width	mm	705	722	722	722	722	722	840	840	840	722	722
R	Breite über Schutzdach width over protection cage	mm	650	660	660	660	660	660	660	660	660	660	660
S	Bodenfreiheit / ground clearance	mm	160	205	205	205	205	205	240	240	240	205	205
T1	max. Radius bei Standard Schaufel 1,40 m max. radius with bucket 1,40m	mm		2400	2450	2400	2450	2650	2430	2505	2680	2400	2450
T2	max. Radius bei Hecküberhang max. radius with rear overhang	mm		-	-	-	-	-	-	-	-	-	-
U	Radius am Außenrand radius over outer edge	mm	1950	1955	1955	1955	1955	1955	2100	2100	2100	1955	1955
V	Innenradius/ inside turning radius	mm	1040	1000	1000	1000	1000	1000	1030	1030	1030	1000	1000
W	Knickwinkel/ angle of articulation	°	45	55	55	55	55	55	55	55	55	55	55
X	Rückrollwinkel bei max. Hubhöhe rollback angle at max.lifting height	°	53	55	50	55	50	54	55	50	54	55	50
Y	max. Auskippwinkel max. dumping angle	°	45	53	47	53	47	42	53	47	43	53	47
Z	Rückrollwinkel am Boden rollback angle on ground	°	40	50	50	50	50	55	50	50	55	50	50
	Leergewicht / empty weight	kg	1010	1360	1410	1360	1410	1460	1570	1620	1670	1360	1410
	Betriebsgewicht/ operating weight	kg	1180	1560	1610	1560	1610	1660	1770	1820	1870	1560	1610

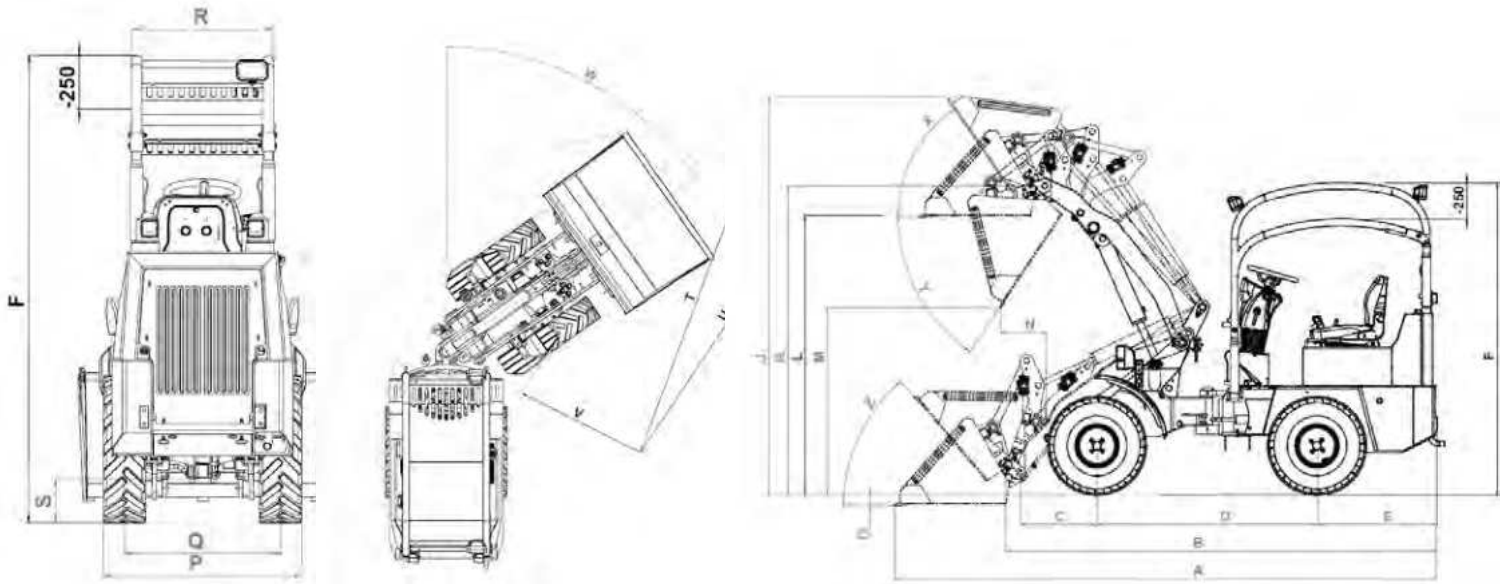

2326L	2326S	2326H	2438L	2438S	2438H	2838L	2838S	2838H	3448L	3448S	3448H	3448L-5A	3448S-5A	3448H-5A
3750	3780	4080	4100	4140	4450	4210	4280	4480	4700	4765	4985	4700	4765	4985
-	-	-	4170	4210	4520	4280	4350	4550	-	-	-	-	-	-
2990	3020	3320	3335	3375	3680	3450	3520	3720	3990	4005	4225	3940	4005	4225
-	-	-	3405	3445	3750	3520	3590	3790	-	-	-	-	-	-
530	550	860	530	550	860	522	592	780	522	592	780	550	620	810
1523	1523	1523	1572	1572	1572	1670	1670	1670	1950	1950	1950	1920	1920	1920
830	830	830	1145	1145	1145	1145	1145	1145	1355	1355	1355	1355	1355	1355
-	-	-	1215	1215	1215	1215	1215	1215	-	-	-	-	-	-
2160	2160	2160	2240	2240	2240	2240	2240	2240	2270	2270	2270	2270	2270	2270
-	-	-	1230	1230	1230	1230	1230	1230	1260	1260	1260	-	-	-
2760	3275	3470	2820	3340	3520	3330	3730	3860	3330	3730	3860	3330	3730	3860
2150	2708	2870	2210	2760	2935	2765	3130	3330	2765	3130	3330	2765	3130	3330
1940	2480	2660	1995	2580	2710	2554	2930	3110	2554	2930	3110	2554	2930	3110
1320	1935	2140	1375	2040	2220	1985	2390	2590	1985	2390	2590	1985	2390	2590
340	325	530	340	330	510	235	310	325	235	310	325	235	310	325
70	70	60	25	25	20	25	55	80	25	55	80	25	55	80
940	940	940	1120	1120	1120	1160	1160	1160	1160	1160	1160	1660	1660	1660
722	722	722	840	840	840	900	900	900	900	900	900	1400	1400	1400
660	660	660	660	660	660	660	660	660	1010	1010	1010	1010	1010	1010
205	205	205	240	240	240	280	280	280	280	280	280	260	260	260
2400	2450	2650	2530	2600	2780	2840	2880	2990	2880	2920	3020	ca. 2980	2980	2980
-	-	-	2280	2280	2280	2470	2470	2470	2720	2720	2720	2730	2730	2730
1955	1955	1955	2100	2100	2100	2400	2400	2400	2382	2382	2382	2420	2420	2420
1000	1000	1000	1030	1030	1030	1230	1230	1230	1210	1210	1210	760	760	760
55	55	55	55	55	55	50	50	50	55	55	55	23+ 4x38°		
55	50	54	55	50	54	51	53	49	51	53	49	49	53	49
53	47	42	53	47	42	47	43	40	47	43	40	47	43	40
50	50	55	50	50	55	50	50	54	50	50	54	54	50	54
1360	1460	1490	1780	1830	1870	1930	1980	2030	2410	2450	2490	2590	2620	2660
1560	1660	1690	1980	2030	2070	2130	2180	2230	2650	2690	2730	2790	2820	2860

Höhe über Kabine (2438/2838/2838T): 2,34m
height over cabin (2438/2838/ 2838T):2,34m

Höhe über Kabine (3448/ 3448T/ 3448-5A): 2,24m
height over cabin (3448/ 3448T/ 3448-5A): 2,24m

Alle Angaben unter Vorbehalt!
Änderungen im Zuge der technischen Weiterentwicklung vorbehalten!
All data are subject to change! Information can change due to further development.

			2838T	3448T	4275T 405/70R20 550/55R22,5 455/65R19,5	4275T 500/45R20	4275T 600/40R22,5	3448T-5A
A	Gesamtlänge mit Schaufel Total length with bucket	mm	4595	5100	5750			5100
B	Gesamtlänge ohne Schaufel Total length without bucket	mm	3895	4340	5070			4340
C	Achsmittle bis Schaufeldrehpunkt axle middle to shovel pivot pin	mm	500	800	1090			800
D	Radabstand/ wheelbase	mm	1680	2050	2300			2050
E	Hecküberhang mit Gewicht rear overhang without/with weight	mm	1215	1355	1470			1354
F	Höhe über Fops-Rops Dach height over FOPS/ROPS protection cage	mm	2240	2260	2510 -2570			2270
J	Gesamtarbeitshöhe Total working height	mm	3870/4620	4664	5540			4664
K	max. Höhe am Schaufeldrehpunkt max. height at shovel pivot pin	mm	3292/4056	3292/4056	3850/4760			3292/4056
L	Überladehöhe/ load-over height	mm	3142/3897	3142/3897	3550/4460		3490/4400	3142/3897
M	max. Ausschütthöhe max. dumping height	mm	2508/3272	2508/3272	3910	3910	3850	2508/3272
N	Reichweite bei M operating distance by M	mm	500/870	500/870	435/850			500/870
O	Schürftiefe/ digging depth	mm	100	40	60	110	100	100
P	Gesamtbreite Standardbereifung total width with standard tires	mm	1380	1386	1800 - 2050			1660
Q	Spurbreite/ track width	mm	1010	1006	1390	1390	1390	1400
R	Breite über Schutzdach width over protection cage	mm	660	1010	1320			1010
S	Bodenfreiheit/ ground clearance	mm	280	280	420	360	420	260
T	max. Radius max. radius	mm	3000	3015	4320			3120
U	Radius am Außenrand radius over outer edge	mm	2530	2967	3650			2510
V	Innenradius Inside turning radius	mm	1100	1257	1720			850
W	Knickwinkel Angle of articulation	°	50	55	45			23 + 4x38°
X	Rückrollwinkel bei max. Hubhöhe Rollback angle at max. height	°	47	47	68			47
Y	max. Auskippwinkel max. dumping angle	°	47	47	40			47
Z	Rückrollwinkel am Boden rollback angle on ground	°	44	39	44			39
	Leergewicht/ empty weight	kg	2540	2800	4900			3200
	Betriebsgewicht/ operating weight	kg	2740	3040	5200			3440

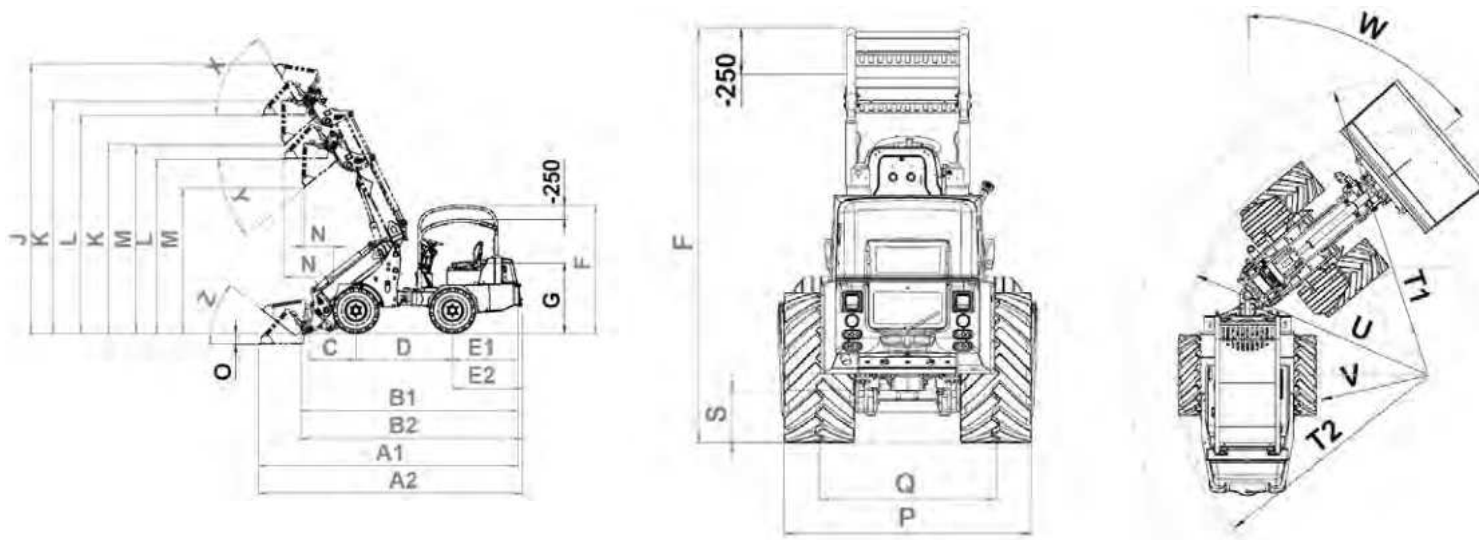

		48T18
A	Gesamtlänge mit Schaufel Total length with bucket	4030 mm
B	Gesamtlänge ohne Schaufel Total length without bucket	3360 mm
C	Achsmittle bis Schaufeldrehpunkt axle middle to shovel pivot pin	660 mm
D	Radabstand wheelbase	2040 mm
E	Hecküberhang rear overhang	450 mm
F	Höhe über Kabine height over cabin	1990 mm
G	Sitzhöhe seat height	1000 mm
H	max. Höhe am Schaufeldrehpunkt max. height at shovel pivot pin	4900 mm
I	Überladehöhe load-over height	3400/4800 mm
J	max. Ausschütthöhe bei 68° max. dumping height at 68°	2620/4000 mm
K	Schüttweite bei 68° Operating distance at 68	290 mm
L	Schüttweite bei 30° operating distance at 30°	880 mm
M	Gesamtbreite Standardbereifung total width with standard tires	1800 mm
N	Spurbreite track width	1400 mm
O	Schürftiefe digging depth	40 mm
P	Bodenfreiheit ground clearance	260 mm
Q	Innenradius inner radius	940 mm
R	Lenkeinschlag Steering angle of all 4 wheels	4 x 38°
S	max. Auskippwinkel max. dumping angle	68°
T	Rückrollwinkel am Boden Rollback angle on ground	46°
	Leergewicht empty weight	3050 kg
	Betriebsgewicht operating weight	3350 kg

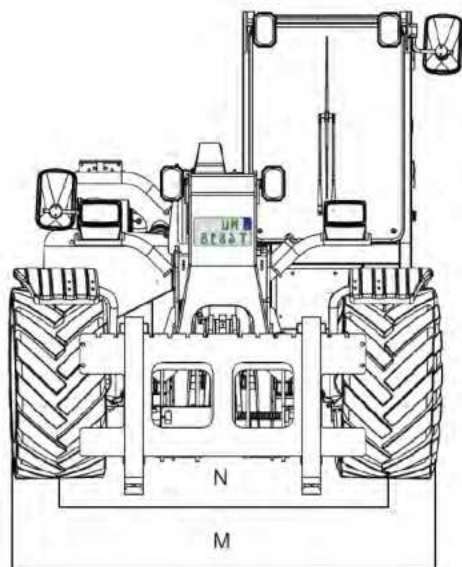
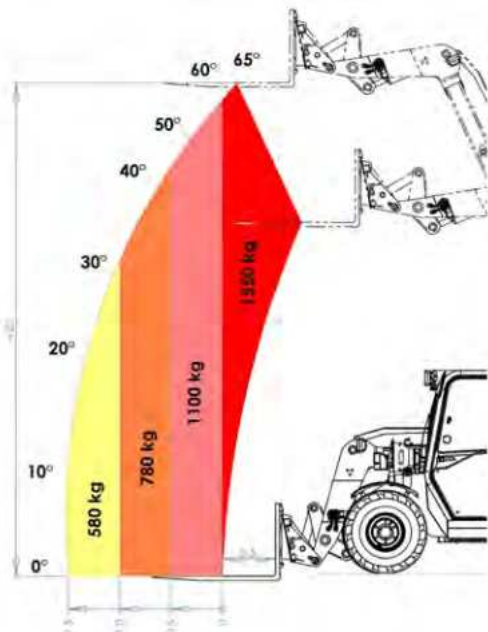
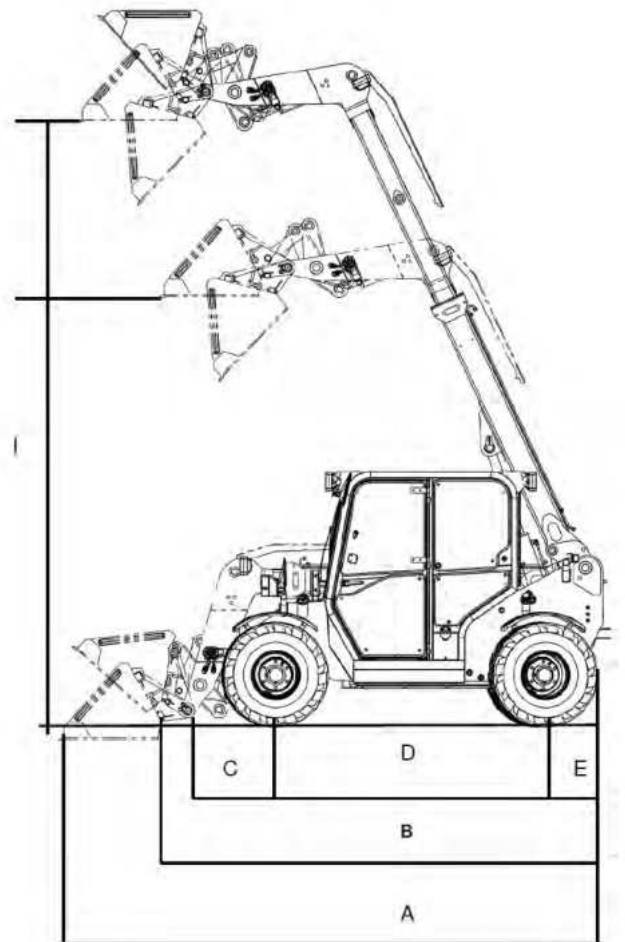

Alle Angaben unter Vorbehalt!
 Änderungen im Zuge der technischen Weiterentwicklung vorbehalten!
 All data are subject to change! Information can change due to further development.

≡ Anbaugeräte/ Attachments

verfügbare Aufnahmen: Thaler-Haken, Thaler-alt, Euro, SMS (mehr auf Anfrage) Anbau an andere Fahrzeuge möglich
 available coupling options: Thaler-Hook-bracket system, Thaler-old, Euro, SMS (more options only on request) coupling to other machinery possible



Standard Schaufel
Standard bucket

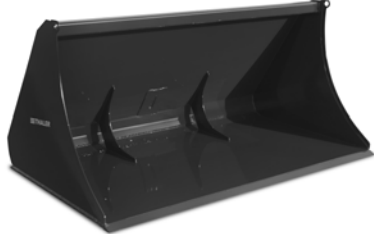

Schaufel (Medium)
Medium bucket

Hochkippschaufel
High-tip bucket



Industrieschaufel
mit/ ohne Zähne
Industrial bucket
with/without teeth



Leichtgutschaufel
High-volume bucket



Schaufel mit Aufsatz
Bucket with hydraulic
grabber



Dungschaufel
Dung bucket



Zwick/ Greifschaufel
Cutting bucket

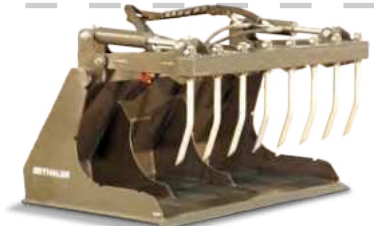

Sperrgutschaufel
mit Aufsatz
Bucket (open sides)
+ grabber



Silogreifschaufel
Power grab bucket



Greifgabel (schwer)
Power grabber (heavy)



Krokodilgebiss
Fork and grab



Federklappenschneeschild
Multi-Section-snow-plow



Güleschieber
Manure/dirt scraper



Futterschiebeschild
Rubber scraper



Faster-Stecker (Option) muss gesondert zu jedem Anbaugerät bestellt werden.
Passt nur zu der Faster Version welche wir anbieten.

Faster plug (option): Must be ordered separately for each attachment.
Only fits for the faster system we are offering.



Palettengabel
Pallet fork



Adapter
Adapter



Einzelaufnahme
Single brackets for previous tools



Krausleger, schwenkbar
Swivelling crane boom



Krausleger starr
Fixed crane boom



Futterdosierschaufel
Feed dosing bucket



Ballenzange
Hydraulic bale grabber



Ballentransport 4 Zinken,
(nur 2 Zinken bei 1220)
Bale fork 4 teeth
(only 2 teeth for 1220)



Einstreugerät
Cubicle Bedder



Trommelmähwerk 1,35m
Drum mower 1,35m



Sichelmähwerk
Rotary mower
Fla



Mulcher
Flail mower



Radialbesen Ø 1m
Radial broom Ø 1m



Kehmaschine
Sweeper



Transportbox
Transportbox

Kehrmaschine Sweeper



Arbeitsbreite operating width	Gesamtbreite total width	Ölmenge oil volume	max. Druck max. pressure
mm	mm	l	bar
1200	1535	35-50	180
1500	1835	35-50	180
1800	2135	35-60	180
2100	2435	35-60	180

1x doppelwirkender Steuerkreis benötigt. Unabhängige Geschwindigkeitregelung empfohlen.

1 x double acting valve required
Independent speed control with high engine REVs
(manual inching with electrical switch recommended)

Grundausrüstung:

mechanische Seitenverstellung, Spritzschutz, 3-Stützrad, Antrieb über Hydraulikmotor, Bürstendurchmesser 520 mm, Kehrwalze 100% PP, Niveau- u. Pendelausgleich.

Optional:

Schmutzsammelwanne mit hydraulischer Entleerung, andere Aufnahme nach Wahl, Seitenbesen, hydraulische Schwenkeinrichtung, Walzen und Seitenbesen in Draht/Kunststoffausführung oder Seitenbesen in Drahtausführung (Wildkrautbesen).

Universell einsetzbar
Verfügbar mit verschiedenen Aufnahmen auch passend für andere Trägerfahrzeuge. Egal ob Euro-, Dreipunkt-, Palettengabel- oder sonstiger Aufnahmen.

Universal use fitting for different machines whether with Euro-, Three-point or palletfork or any other coupling system.

Standard equipment:

Mechanical lateral adjustment, splash guard, carrying frame with 3 support wheels and levelling + pendulum compensation, driven by hydraulic motor, brush - diameter 520 mm, sweeping roller: 100% PP

Option:

Different bracket systems available. Dirt collecting box with hydraulic operation for emptying, side brush, hydraulic pivoting device, rollers and side brush made of wire + plastic fill or side brush only made of wire fill like a weed brush.



Nachrüsten des Seitenbesen und Sammelwanne möglich. Die Teile können mit wenigen Handgriffen ab- oder angebaut werden.

Die Kehrmaschine ist serienmäßig mit Niveau- und Pendelausgleich ausgestattet. Daher wird die Kehrmaschine immer optimal über den Boden geführt und passt sich den Gegebenheiten an. Die Schwerlastrollen sind separat höhenverstellbar.

Retrofitting of the side brushes and collection tray is possible. The parts can be removed or attached in a few simple steps.

The sweeper is equipped with level and pendulum compensation as standard. Therefore, the sweeper is always optimally guided over the ground and adapts to the conditions. The heavy-duty castors are individually height-adjustable.

Schlegelmulcher Flail mower

Arbeitsbreite operating width	Gesamtbreite total width	Ölmenge oil volume	max. Druck max. pressure
mm	mm	l	bar
1330	1640	35-60	180
1700	2000	35-60	180

1x doppelwirkender Steuerkreis sowie druckloser Rücklauf wird benötigt.
Unabhängige Geschwindigkeitregelung empfohlen.
1 x double acting valve and pressure free return line required
Independent speed control with high engine REVs
(manual inching with electrical switch recommended)



Anbau mit Niveau-
u. Pendelausgleich
Adapter plate with levelling
and pendulum compensation

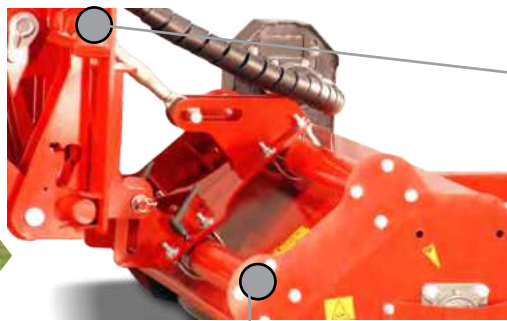

leistungsstarker Ölmotor
(mit schonendem Freilauf
bei Abschaltung)
powerful hydraulic motor
with freewheel for protection
when switched off

Universell einsetzbar
Verfügbar mit verschiede-
dene Aufnahmen auch
passend für andere Träger-
fahrzeuge. Egal ob Euro-
Dreipunkt-, Palettengabel-
oder sonstiger Aufnahmen.
Universal use
fitting for different machines
whether with Euro-, Three-
point or palletfork or any
other coupling system.

manuell seitlich
verschieben
möglich
coverage of the
manual lateral
shifting to cut
closer to obstacles

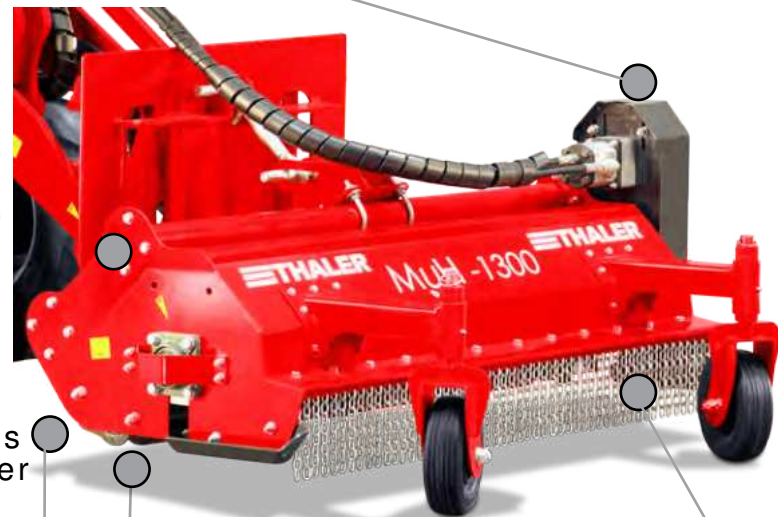

breite Ablage des
Mulchgutes hinter
der Stützwalze
wide and equal
coverage of the
mulch behind the
support roller

Kettenvorhang
protective chain curtain

höhenverstellbare Stützwalze
mit runden Enden
zur Bodenschonung
height-adjustable support roller
with rounded ends to protect
the soil and the vegetation



Kurzhäckselleiste
schraubbar verfügbar
bolt-on counter blades
available

Rotorwelle mit spiralförmig angeordneten
Schlegelhaltern für optimale Kraftausnutzung
Rotor shaft with spiral-shaped flail holders
for a best power use

Federklappenschneeschild Spring Flap Snowplough

Schildbreite Total width Plough	Räumbreite Working width	Gewicht Weight
mm	mm	kg
1200	850-1000	220
1600	1200-1400	245
2000	1600-1800	270
2400	2000-2200	295
2800	2400-2600	340



Optional
Begrenzungsleuchte
Vulkolanräumleiste

Optional
Position lights
Scraping blade out of Vulkolan

mit extra Thaler
verschleißbarer
Konstruktion der
Räumleiste
with Thaler low-wear
construction for the
blade.

Grundausrüstung:

- verschleißbarer Hardoxstahl
- Federklappen als Anfahrerschutz
- Parallelogramm
- Pendelausgleich
- hydraulische Seitenverstellung
- hochwertige Materialien
- Sandgestrahlt, grundiert, lackiert
- Abstellfüße
- Randsteinabweiser
- schwenkbar 40°

Standard equipment:

- Hardox steel for low wear
- Spring-loaded flaps as protection when hitting obstacles
- Parallelogram and pendulum compensation
- hydraulic pivoting device
- High-quality materials and components
- Sandblasted, primer coated and varnished
- 2 supporting parking jacks
- Deflector
- swivelling 40°

weitere Anbaugeräte nur auf Anfrage
different attachments only on request



Schneefräse nur
auf Anfrage
snow blower only on request

Einstreugerät mit Förderband Cubicle Bedder with conveyor belt

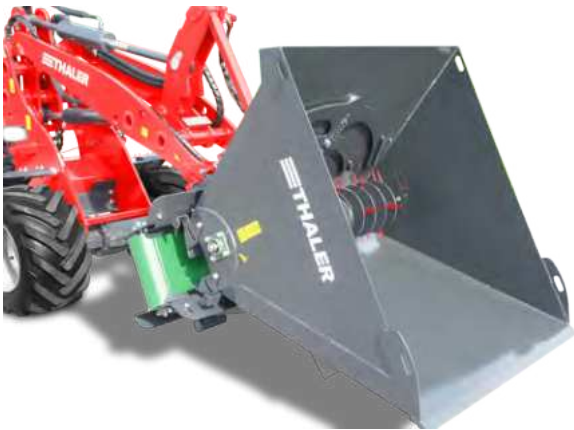

Einstreugerät Cubicle bedder	Schildbreite Total width Plough	Räumbreite Working width	Fassungsvermögen Capacity	Fassungsvermögen Capacity	Gewicht Weight
	mm	mm	m	l	kg
1,25m	1250	1550	1	1250	360
1,50m	1500	1800	1,2	1500	400
1,70m	1750	2050	1,3	1750	425

Grundausrüstung:

- Ölmotor für leistungsstarken Antrieb
- Wurfweite je nach Einstreumaterial bis zu 3 m
- Auswurf links oder rechts möglich

Standard Equipment:

- Robust hydraulic motor for powerful drive
- Throwing distance up to 3 m depending on the bedding material
- Discharge either to the left either to right

Geeignet für viele Streugüter z.B. :

- Stroh
- Kalkstrohgemisch
- Kompost
- separierte Gülle
- Sägespäne
- Pferdemist, und vieles mehr...

Functions with many materials such as:

- Straw
- Mixture out of straw with lime and water
- Compost
- Sawdust
- Horse manure/manure
- Separated slurry etc.



Datum / Date



A series of 27 horizontal lines spaced evenly down the page, providing a template for handwritten notes or a list.

NEUN GUTE GRÜNDE FÜR LADER VON THALER:

1. Qualität aus Deutschland mit eigener Produktion & Entwicklung in Bayern
2. Hohe Individualisierung - jeder Lader entspricht genau Ihren Anforderungen und Wünschen
3. Handwerklich hochwertige Fertigung in Bayern von spezialisierten Fachkräften für beste Materialien und erstklassige Verarbeitung
4. Top-Technologie in der Produktion für jedes einzelne Bauteil sowie für Motorisierung und Antrieb
5. Maximal verlässliches Qualitätsmanagement für hohe Langlebigkeit
6. Niedrige Servicekosten durch wartungsfreundliche Konstruktion
7. 25 Jahre Thaler - Unternehmen in dritter Generation
8. Einfach zu bedienen und top-ergonomisch ausgestattet
9. Schnelle und unkomplizierte Serviceabwicklung mit langjährigen Servicepartnern und Händlern in ganz Europa

NINE GOOD REASONS FOR LOADERS FROM THALER:

1. Quality from Germany with in-house production and development in Bavaria
2. High level of customization - every loader corresponds exactly with your requirements and wishes
3. High-quality craftsmanship in Bavaria by specialized professionals with the best materials and first class workmanship
4. Top technology in production for each individual component as well as for motorization and drive
5. Maximum reliable quality management for long service life
6. Low service costs due to maintenance-friendly design
7. 25 years of Thaler - A company in its third generation
8. Easy to use and highly ergonomically equipped
9. Fast and direct service and support from long-standing service partners and dealers throughout Europe.



 Thaler GmbH & Co. KG
Weidinger Straße 24
84570 Polling
Germany

 +49 (0) 8633 50550 - 0
 +49 (0) 8633 50550 - 10
 info@hoflader.com
 www.hoflader.com

Wir freuen uns auf Ihren Anruf oder Ihre E-Mail mit einer Anfrage.
We look forward to your call or email with an inquiry or other requests.

Jetzt mit unseren Ladern durchstarten!

Schluss mit der Arbeit, her mit der Freizeit! Unsere Hoflader, Radlader, Teleskoplader und 5-Achsenlenker sparen Ihnen jede Menge Zeit. Sprechen Sie uns an. Unsere Werksvertreter und Händler in Deutschland sowie unsere Importeure in Europa beraten Sie gerne individuell und unverbindlich.

Kontakt Daten Ihres Händlers:

Get started now with our loaders!

Work smart, not hard! Our yard loaders, wheel loaders, telehandlers and 5-axle steering loaders simply save you a lot of time. Contact us. Our factory representatives and dealers in Germany as well as our Importers in Europe will be happy to advise you individually and without obligation.

Contact details of your dealer: